

Emergency Valve

**2000**

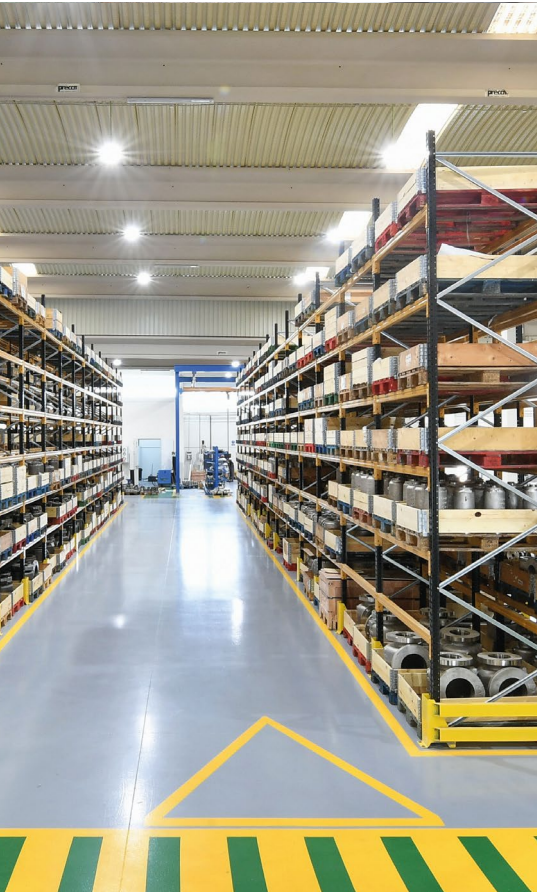

## ■ The Company



## Production, R+D+i, evolution

VALVULAS NACIONAL, S.A. was established in Spain in 1976. The main target was to assist the petrochemical and chemical industries emerging in Spain at that time. Right from the start VALVULAS NACIONAL, S.A., has been designing and producing safety valves according to most recognized international standards and norms: API, ASME, ASTM and the European directives 2014/68/UE and 2014/34/UE. Our production process is accredited by an ISO 9001-2015 certification.

Our know how and capacity to adapt to the constantly changing demands of the market, made possible the introduction of new products designed for new applications on the market, like THERMOSOLAR PLANTS, where VALVULAS NACIONAL has supplied safety valves to more than 31 complete plants all over the world, while at the same time continuously supplying to all main players of the Spanish petrochemical, chemical and refining industries.

## Production capacity

VALVULAS NACIONAL, S.A. valves' have their discharge coefficients approved in laboratory tests, in order to guarantee and assure that correct values are being used for every sizing process.

In our Technical sales department we count with a modern software which allows us to verify all the possibilities, and to assure strict fulfillment of all international standards.

VALVULAS NACIONAL, S.A. has established representation agreements with the most important O.E.M. companies in the safety sector of the industry, consolidating us as one of the main companies by product range; design and consulting in new plants or in new process.

Our continuous growth, shows a clear trend, which confirms the integration of our workers to provide first class service to our customers and partners.

## Factory & location

Our facilities in Rubí (Barcelona - Spain), with more than 3.000 Sq m are fully prepared for our production activities: machining with modern CNC, assembling and testing. We also have long term agreements with approved workshops, which provides us with flexibility and fast feedback to customers demands, with full quality guarantee which has always been our main target.

## Strategic alliances

Nowadays VALVULAS NACIONAL, S.A. starts an internationalization process, establishing representation agreements in different countries and continents all over the world, with specialized companies that will provide added value in our service towards the end user.

**VALVULAS NACIONAL Making safety since 1976!**



## ■ Index

GENERAL FEATURES & DESCRIPTION	4
DIMENSION	5
BILL OF MATERIALS	6
DEFINITIONS	7

**VALVULAS NACIONAL**

Making safety  
since 1976



## ■ General Features

### Product Introduction

The emergency valve, model "PH", is a safety device intended for installation on storage tanks with the finality of assure a quick evacuation of large volume of fluid inside the tank in the event of an overpressure due to fire condition.

Another purpose is that due to its peculiar design and size, it can be used as a manhole cover, allowing access to the interior of the container. That allows easily to do maintenance and inspection of the interior of the tank.

### Description

The emergency valve "PH" is designed in such a way that its opening occurs when the fluid contained in the tank creates a pressure higher than its set pressure value. When the overpressure causes more force on the valve disc than the weight of the valve, the disc will rise, allowing fluid leakage and, consequently, relief of overpressure. The valve will be closed again, once the pressure inside the tank has stabilized.

The emergency valve basically consists of a flanged body to install the valve to the tank. A weight controlled floating disc, attached by a link to the manual opening lever, which in turn is attached to the body by a hinge. The sealing of the seal between the cover and the body is produced by means of a diaphragm or oring.

The quality of the materials and the sealing elastomer are defined according to the pressure, temperature and chemical characteristics of the product stored in the tank to which the valve is to protect.

Because the cover is electrically isolated from the valve body by the sealing diaphragm and by the hinge friction bushes, which are made of PTFE, a ground cable is installed that electrically joins the two parts, allowing the static electricity that could accumulate the cover due to its insulation, passes to the body and form it to the tank through the fixing bolts, thus eliminating the risk of electrostatic discharges in installations with potentially explosive atmospheres.

### Codes and Standars

European Directive: ..... 2014/34/UE (ATEX)

Quality System: ..... EN ISO 9001:2015

Materials: ..... ASME/ASTM & EN

### Sizes and Ratings

#### ASME B16.34:

Sizes: ..... 16" / 20" / 24"

Rating: ..... 150#

#### EN 1092-1:

Sizes: ..... DN400 / DN500 / DN600

Rating: ..... PN10

#### API 650:

Sizes: ..... 16" / 20" / 24"

Rating: ..... -

Different rating than the standard can be supplied.

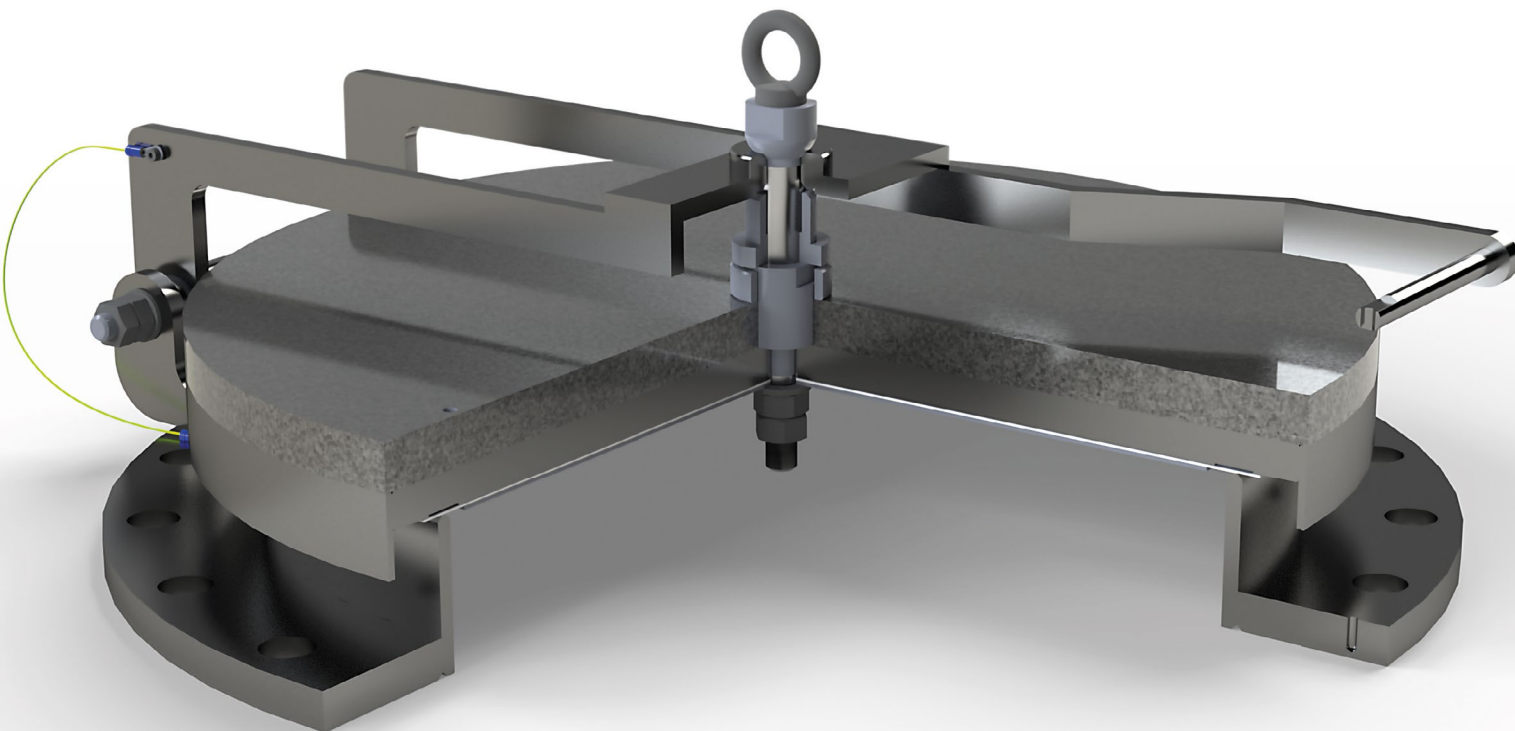

## ■ Dimension

	SET PRESSURE	DIMENSION (mm)		
	(mmwg)	A	B	C
16" / DN400	50	595	307,5	170
	100 ÷ 400	595	307,5	195
	450 ÷ 500	570	285	195
20" / DN500	50 ÷ 250	712	360,5	182
	300 ÷ 450	765	360	212
	500 ÷ 550	765	360	225
24" / DN600	50 ÷ 300	818	409	180
	300 ÷ 500	818	409	210
	550	818	409	220

		RATING	ØD (mm)	ØE (mm)	ØF (mm)	N° OF HOLES
16" / DN400	API 650	-	535	464	19	12
	ASME B16.5	150#	600	650	28,5	16
	EN 1092-1	PN-10	570	515	26	16
20" / DN500	API 650	-	663	597	19	16
	ASME B16.5	150#	703	635	32	20
	EN 1092-1	PN-10	673	620	26	20
16" / DN400	API 650	-	765	699	19	20
	ASME B16.5	150#	818	749,3	35	20
	EN 1092-1	PN-10	783	725	30	20

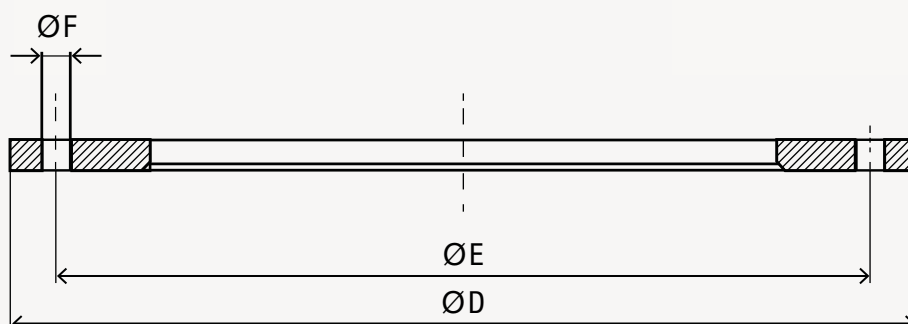
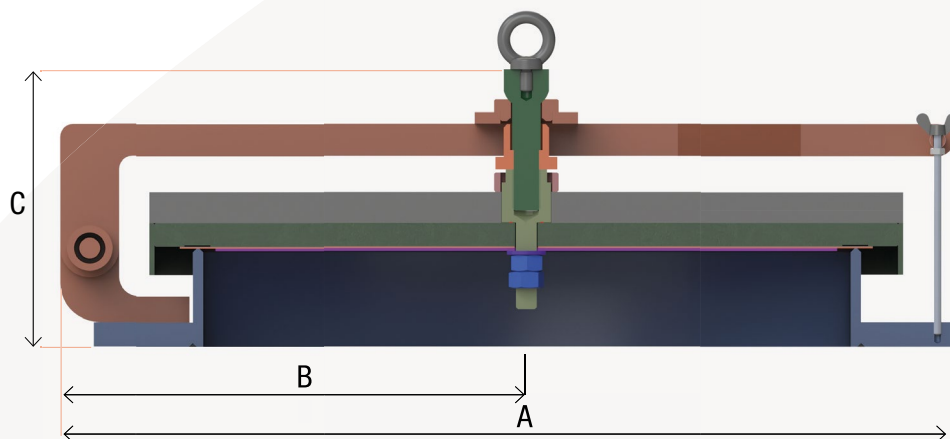



## ■ Bill of materials

ITEM	DESCRIPTION	MATERIAL
1	BODY	AISI 316
2	BONNET	AISI 316
3	LEVER	AISI 316
4	SLEEVE	PTFE
5	LEVER STUD	AISI 316
6	STEM	AISI 316
7	MAIN GASKET	PTFE
8	STEEL SHEET	AISI 316
9	MAIN GASKET DISC	AISI 316
10	LEVER SHAFT	AISI 316
11	WEIGHT SHAFT	AISI 316
12	SLEEVE	AISI 316
13	WEIGHT	AISI 316 / C.S.
14	WEIGHT	AISI 316 / C.S.
15	THREADED BAR	AISI 316
16	GASKET	COMPR. FIBERS
17	NUT	A4 S.S.
18	WASER	A4 S.S.
19	WASER	A4 S.S.
20	NUT	A4 S.S.
21	LIFTING EYE BOLT	A4 S.S.
22	WING NUT	A4 S.S.

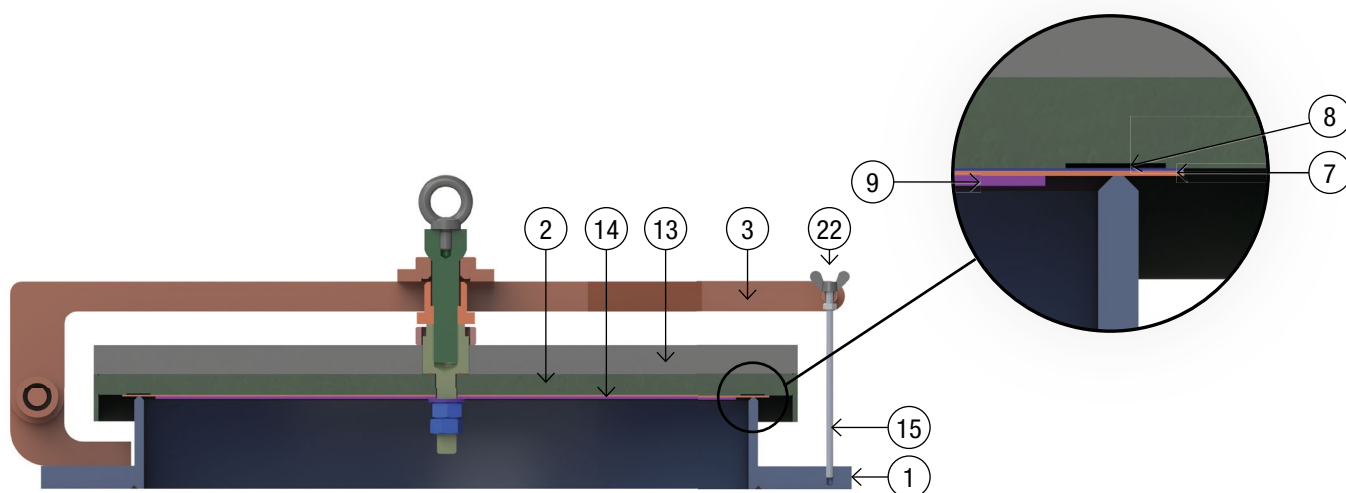
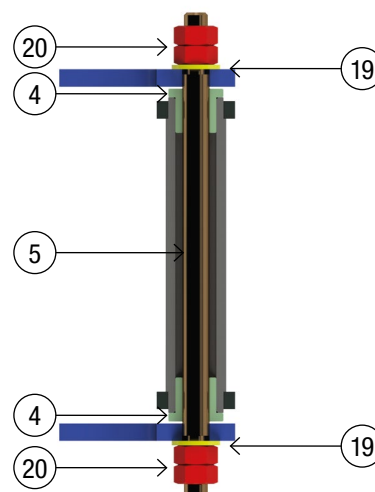
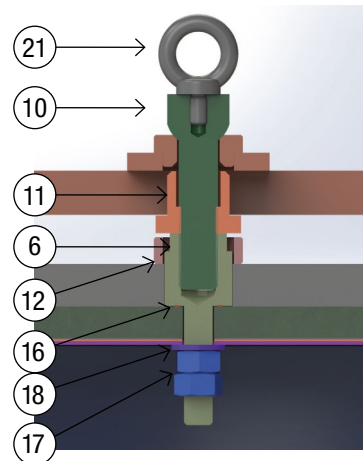

## ■ DEFINITIONS (ISO 28300 / API Standard 2000)

- **Accumulation:** Pressure increase over the maximum allowable working pressure or design pressure of the vessel allowed during discharge through the pressure-relief device.
- **Adjusted set pressure:** Inlet static pressure at which a pressure-relief valve is adjusted to open on the test stand.
- **British thermal unit (Btu):** Unit of heat that increases the temperature of one pound of water by one degree Fahrenheit.
- **Emergency venting:** Venting required when an abnormal condition, such as ruptured internal heating coils or an external fire, exists either inside or outside a tank.
- **Non-refrigerated tank:** Container that stores material in a liquid state without the aid of refrigeration, either by evaporation of the tank contents or by a circulating refrigeration system.
- **Normal cubic metres per hour (Nm<sup>3</sup>/h):** SI unit for volumetric flow.
- **Normal venting:** Venting required because of operational requirements or atmospheric changes.
- **Overpressure:** Pressure increase at the PV valve inlet above the set pressure, when the PV valve is relieving.
- **Petroleum:** Crude oil.
- **Petroleum products:** Hydrocarbon materials or other products derived from crude oil.
- **PV valve:** Weight-loaded, pilot-operated, or spring-loaded valve, used to relieve excess pressure and/or vacuum that has developed in a tank.
- **Rated relieving capacity:** Flow capacity of a relief device expressed in terms of air flow at standard or normal conditions at a designated pressure or vacuum.
- **Refrigerated tank:** Container that stores liquid at a temperature below atmospheric temperature with or without the aid of refrigeration, either by evaporation of the tank contents or by a circulating refrigeration system.
- **Relief device:** Device used to relieve excess pressure and/or vacuum that has developed in a tank.
- **Relieving pressure:** Pressure at the inlet of a relief device when the fluid is flowing at the required relieving capacity.
- **Required flow capacity:** Flow through a relief device required to prevent excessive pressure or vacuum in a tank under the most severe operating or emergency conditions.
- **Rollover:** Uncontrolled mass movement of stored liquid, correcting an unstable state of stratified liquids of different densities and resulting in a significant evolution of product vapour.
- **Standard cubic feet per hour (SCFH):** USC unit for volumetric flow rate of air or gas (same as free air or free gas) at a temperature of 15,6 °C (60 °F) and an absolute pressure of 101,3 kPa (14,7 psi), expressed in cubic feet per hour.
- **Set pressure:** Gauge pressure at the device inlet at which the relief device is set to start opening under service conditions.
- **Thermal inbreathing:** Movement of air or blanketing gas into a tank when vapours in the tank contract or condense as a result of weather changes (e.g., a decrease in atmospheric temperature).
- **Thermal out-breathing:** Movement of vapours out of a tank when vapours in the tank expand and liquid in the tank vaporizes as a result of weather changes (e.g., an increase in atmospheric temperature).
- **Wetted area:** Surface area of a tank exposed to liquid on the interior and heat from a fire on the exterior.

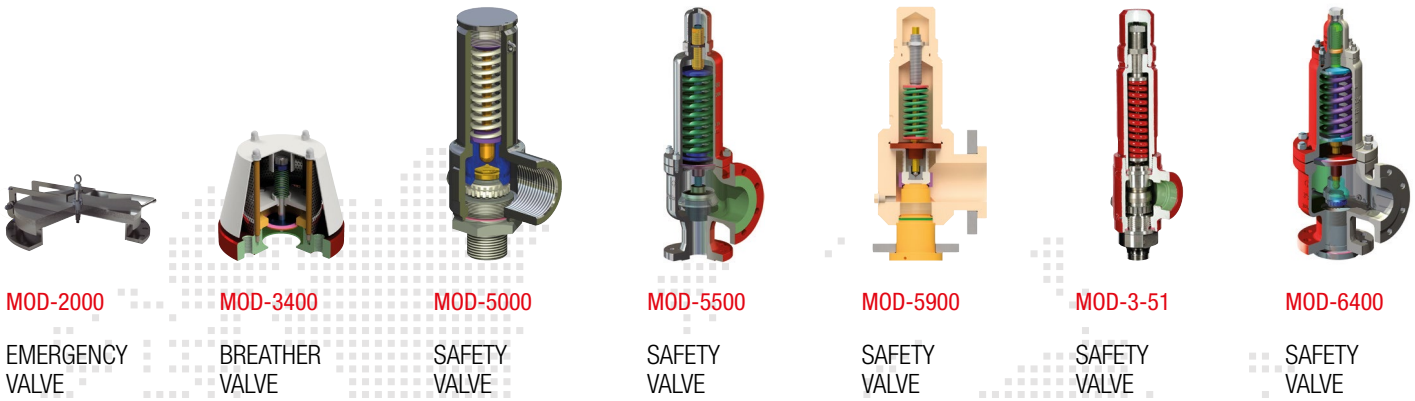

**MOD-2000**

**EMERGENCY VALVE**

**MOD-3400**

**BREATHER VALVE**

**MOD-5000**

**SAFETY VALVE**

**MOD-5500**

**SAFETY VALVE**

**MOD-5900**

**SAFETY VALVE**

**MOD-3-51**

**SAFETY VALVE**

**MOD-6400**

**SAFETY VALVE**

Making safety. since 1976